

Installation and Service Instructions for 54,000 Series (rev. A)

Manual Adjust Brakes

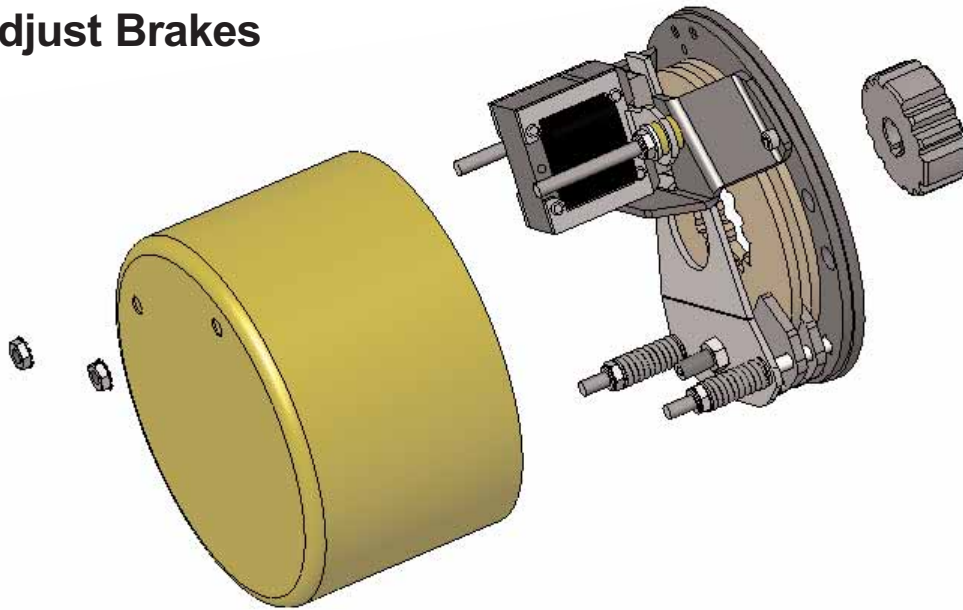

Typical Nameplate

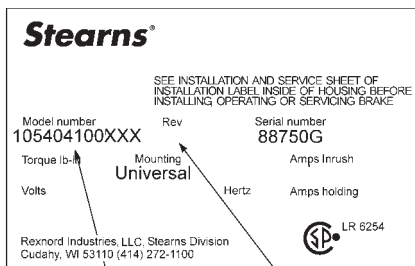

MODEL NUMBER
Refer to actual nameplate on
brake for additional information

REVISION CONTROL
(if applicable) and
Brake Serial Number

Important

Please read these instructions carefully before installing, operating, or servicing your Stearns brake. Failure to comply with these instructions could cause injury to personnel and/or damage to property if the brake is installed or operated incorrectly. For definition of limited warranty/liability, contact Rexnord Industries, LLC, Stearns Division, 5150 S International Drive., Cudahy, WI 53110, (414) 272-1100.

Caution

1. Installation and servicing must be made in compliance with all local safety codes including Occupational Safety and Health Act (OSHA). All wiring and electrical connections must comply with the National Electric Code (NEC) and local electric codes in effect.
2. Do not install the brake in atmospheres containing explosive gases or dusts.
3. To prevent an electrical hazard, disconnect power source before

working on the brake. If power disconnect point is out of sight, lock disconnect in the *off* position and tag to prevent accidental application of power.

4. Be certain power source conforms to the requirements specified on the brake nameplate.
5. Be careful when touching the exterior of an operating brake. Allow sufficient time for brake to cool before disassembly. Surfaces may be hot enough to be painful or cause injury.
6. Do not operate brake with housing removed. All moving parts should be guarded.
7. Installation and servicing should be performed only by qualified personnel familiar with the construction and operation of the brake.
8. For proper performance and operation, only genuine Stearns parts should be used for repairs and replacements.
9. After usage, the brake interior will contain burnt and degraded friction material dust. This dust must be removed before servicing or adjusting the brake.

DO NOT BLOW OFF DUST using an air hose. It is important to avoid dispersing dust into the air or inhaling it, as this may be dangerous to your health.

- a) Wear a filtered mask or a respirator while removing dust from the inside of a brake.
- b) Use a vacuum cleaner or a soft brush to remove dust from the brake.

When brushing, avoid causing the dust to become airborne. Collect the dust in a container, such as a bag, which can be sealed off.

General Description

This series brake is spring set, electrically released. These brakes will contain one or two friction discs (4) driven by a hub (16) mounted on the motor or other drive shaft.

Operating Principle

When the brake coil is energized the lever arm retracts the spring force from the disc pack, allowing the friction disc to rotate with the hub and motor shaft. When power is removed the lever arm pushes down on the stationary disc and friction discs. The hub is held from rotating, and the load is held in place.

Caution! Some brakes are equipped with a manual release to allow for some shaft rotation. This feature is designed with an automatic reset that resets the release when power is reapplied to the brake coil. The brake is not intended to run with the release engaged.

Warning! Any mechanism or load held in place by the brake should be secured to prevent possible injury to personnel or damage to equipment before any disassembly of the brake is attempted or the manual release lever is operated on the brake.

Note: This brake can be mounted in any position. The brake is secured to the motor using two screws mounted 180° apart.

BRAKE MOUNTING (Manual Adjust)

1 Place hub on motor shaft.

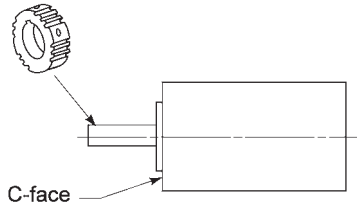

2 Position hub on shaft as shown.

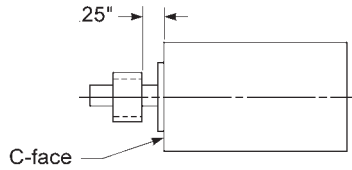

3 Tighten set screws to motor shaft.

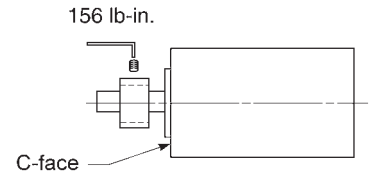

4 Remove brake housing and gasket.

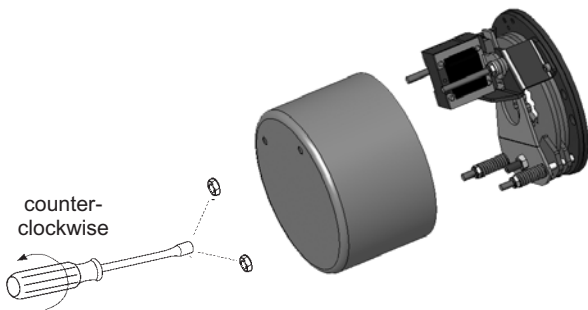

5 Align friction disc with splined hub and slide brake against motor face. (If brake is equipped with a stabilizing clip, it must be positioned opposite the set screw locations).

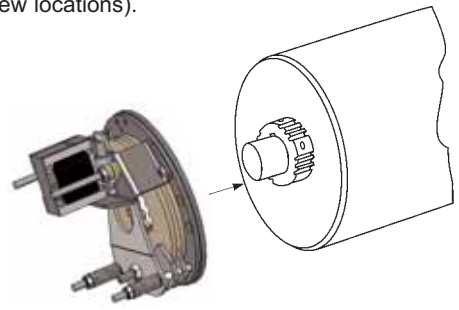

6 Insert mounting screws and tighten.

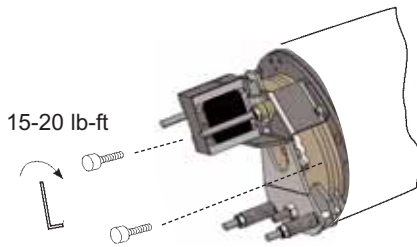

7 Connect coil leadwires to power supply. Refer to nameplate for voltage rating.*
Caution: Keep wiring away from pinch points and moving components.

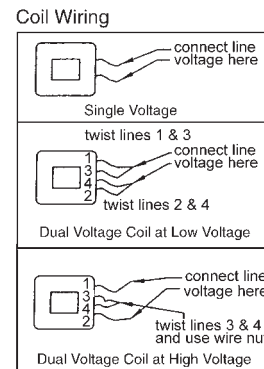

8 Replace brake housing and tighten to 8 lb-in.

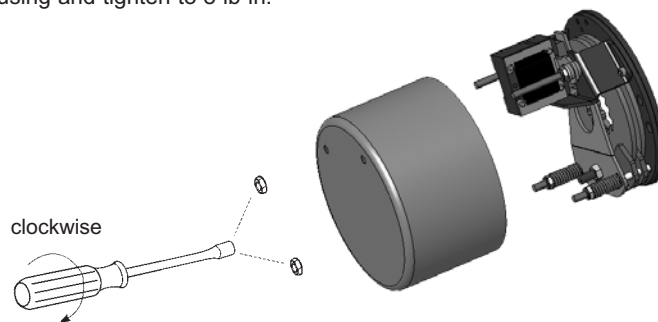

AIR GAP ADJUSTMENT

Brake air gaps are factory adjusted to .100". As friction discs wear the air gap will increase. When the gap reaches .200" it will need to be readjusted to .100".

1. Loosen jamb nut (10N).
2. Turn adjusting screw (10) CW until .100" gap is reached (see Fig. 1).
3. Retighten jamb nut.
4. Check air gap again...

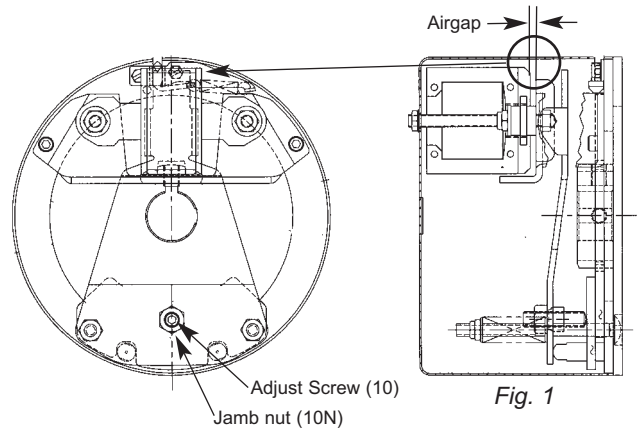

TORQUE ADJUSTMENT

The brake is factory set for nominal rated torque. No further adjustment to increase torque may be made. The approximate compressed torque spring height is shown below. Torque reduction may not exceed 1 full turn in the CCW direction (1.5 lb-ft brake cannot be reduced). Note that the spring measurement for the 6 and 9 lb-ft spring is from inside the shoulder washer.

Brake Torque (lb-ft)	Length "L" (in.) (± .02)	Max Torque Reduction (cw turn of torque nut)	% Reduction
1.5	1.10	0	0
3	.95	1	15
6	1.29	1	25
9	1.19	1	15

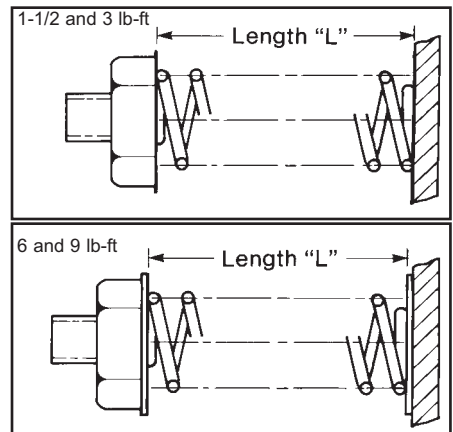

FRICTION DISC REPLACEMENT

1. Remove the two brake mounting screws and lift the brake assembly from the hub / motor.
2. Remove the two support bracket screws (3s), and lift the brake and solenoid assembly (3) off the brake.
3. Lift the lever arm (17) forward and slide the friction disc(s) out of the brake assembly.
4. Insert new friction disc(s) under the stationary disc (5). If brake has two friction discs align the center spline holes with each other.
5. Align the brake and friction disc assembly on the hub (16) and slide onto the motor. Insert and tighten the two brake mounting screws (15-20 lb-ft).
6. Reposition the support bracket assembly (3) on the brake, and retighten the two support bracket screws (3s), (52 lb-in).

Note: Air gap readjustment will be required after disc replacement.

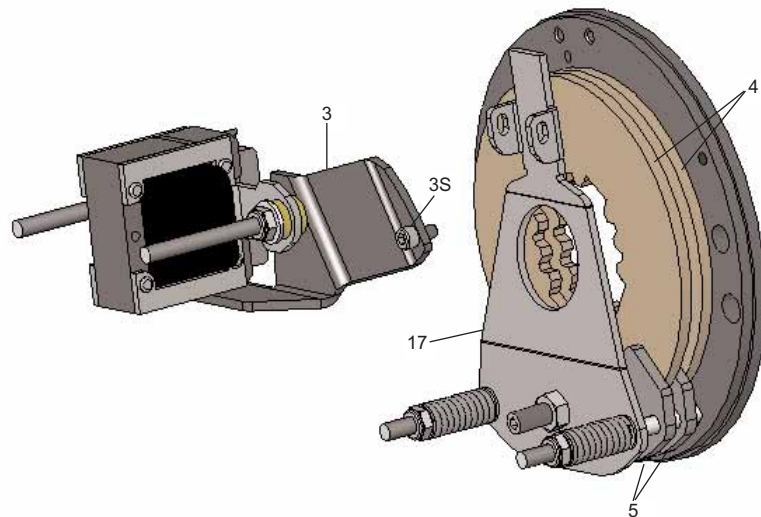

COIL REPLACEMENT

1. Remove the two support bracket screws (3s), and lift the bracket and solenoid assembly (3) off the brake.
2. Remove the plunger guide (140) from the inside of the coil.
3. Remove the tap-bolt (160) from the leadwire side of the coil by backing off the lock-nut (210). Slide the bolt, shock mount pads and flat washer out of the way.
4. Remove the coil (12) from the solenoid frame (79) by pushing down on the coil locking tab on the side opposite the leadwires. Push the coil out of the frame.
5. Insert the new coil into the solenoid frame in reverse of the steps of removal. Insert the new plunger guide (140) into the coil, locking tabs first.
6. Position a shock mount pad (150) on both sides of the solenoid mounting bracket, and reinsert the tap-bolt (160) through the shock pads and bracket.
7. Slide a flat washer (170) over the bolt, and tighten the locknut down until the shock pads begin to flatten (30 lb-in).
8. Position the solenoid and bracket assembly (3) over the plunger (29) and slide into place. Tighten the bracket mounting screws (3s) to 52 lb-in.
9. Reassemble brake motor by following steps 5-8 of the brake mounting procedure.

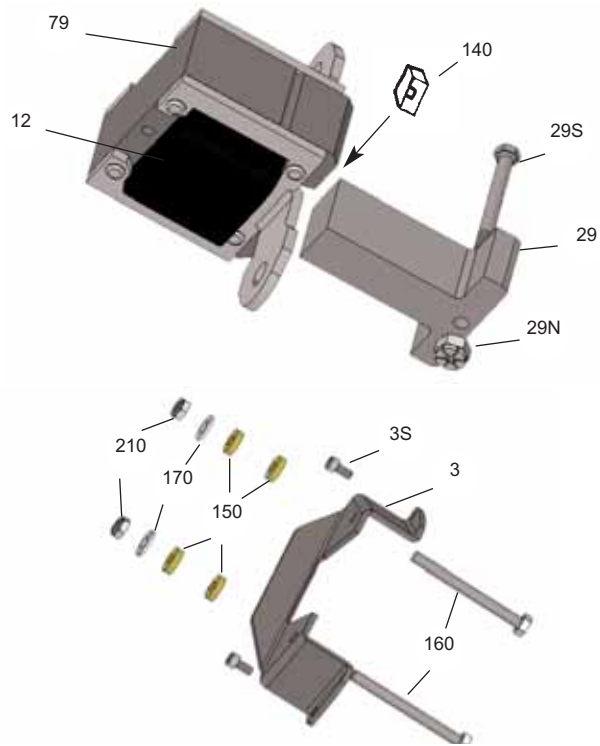

SOLENOID REPLACEMENT

1. Remove the two support bracket screws (3s), and lift the bracket and solenoid assembly (3) off the brake.
2. Remove the plunger guide (140) from the inside of the coil.
3. Remove both tap-bolt (160) from the solenoid assembly (79).
4. Remove the coil (12) from the solenoid frame (79) by pushing down on the coil locking tab on the side opposite the leadwires. Push the coil out of the frame.
5. Insert the coil into the new solenoid frame in reverse of the steps of removal. Insert the new plunger guide (140) into the coil, locking tab first.
6. Position the new shock mount pad (150) on both sides of the solenoid mounting bracket, and reinsert the tap-bolts (160) through the shock pads and bracket.
7. Slide the flat washers (170) over the bolt, and tighten the locknut down until the shock pads begin to flatten (30 lb-in).
8. Remove the plunger nut (29N) and screw (29S), and lift plunger (29) from lever arm (17). Install the new plunger to the lever arm using the new screw and nut provided. Tighten to 30 lb-in.
9. Position the solenoid and bracket assembly (3) over the plunger (29) and slide into place. Tighten the bracket mounting screws (3s) to 52 lb-in.
10. Reassemble brake to motor by following steps 5-8 of the brake mounting procedure.

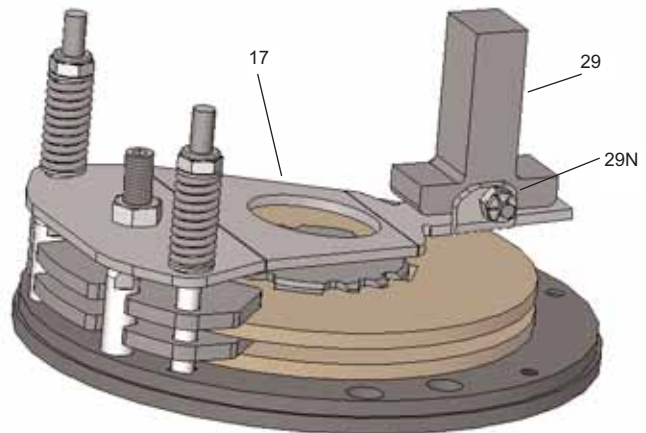

TROUBLESHOOTING

COIL FAILURE	
SUPPLY VOLTAGE CAUSE	SUPPLY VOLTAGE CORRECTION
Line voltage >110% of coil rating	Reduce voltage or replace with proper rated coil
AC input on a DC coil	Replace rectifier or replace with proper rated coil.
Excessive voltage drop during inrush time	Increase current rating of power supply.
WIRING CAUSE	WIRING CORRECTION
Leadwires interfering with plunger pull-in	Reroute wiring away from plunger and other moving components.
Coil leadwire shorted to ground	Replace coil or leadwire and protect with wire sleeving
SOLENOID ASSEMBLY CAUSE	SOLENOID ASSEMBLY CORRECTION
Plunger not seating flush against solenoid frame	Loosen solenoid mounting nuts and reposition frame to allow full face contact
Excessive solenoid/plunger wear at mating surface	Replace solenoid assembly
Broken shading coils	Replace solenoid assembly
WORN PARTS CAUSE	WORN PARTS CORRECTION
Excessive wear of solenoid link bolt	Replace link bolt; also inspect plunger thru-hole for elongation
Plunger guide worn down and interfering with plunger movement	Replace guide
APPLICATION CAUSE	APPLICATION CORRECTION
Machinery cycle rate is exceeding brake rating	Reduce brake cycle rate or use alternate control method
High ambient temperature (>110%) and thermal load exceeding coil insulation rating	Use Class H rated coil and /or find alternate method of cooling brake
Brake coil wired with windings of an Inverter motor or other voltage/current limiting device	Wire coil to dedicated power source with instantaneous coil rated voltage
MISCELLANEOUS CAUSE	MISCELLANEOUS CORRECTION
Wrong or over tightened torque springs	Replace with proper spring or refer to Installation section for proper spring height
Excessive air gap	Reset, refer to Airgap Adjustment

EXCESSIVE WEAR / OVERHEATING	
AIR GAP CAUSE	AIR GAP CORRECTION
Low solenoid air gap	Reset air gap (refer to Air Gap Adjustment)
Disc pack dragging	Inspect endplate, hub and discs for dirt, burrs, wiring and other sources of interference preventing disc "float"
CYCLE RATE CAUSE	CYCLE RATE CORRECTION
Brake "jogging" exceeding coil cycle rate	Reduce cycle rate or consider alternate control method
Thermal capacity is being exceeded	Reduce cycle rate, use alternate control method or increase brake size
ALIGNMENT CAUSE	ALIGNMENT CORRECTION
Broke endplate not concentric to motor C-Face	Motor register must be within .004" on concentricity.
Motor shaft runout is excessive	Must be within .002"; runout; consult motor manufacturer
WORN PARTS CAUSE	WORN PARTS CORRECTION
Friction disc excessively worn (disc can wear to 1/2 original thickness or .093")	Replace friction discs.
Endplate, stationary disc or pressure plate warped	Replace warped or worn component
Linkages worn	Replace all worn components
Motor shaft endfloat excessive	Endfloat must not exceed .020"; consult motor manufacturer
HUB CAUSE	HUB CORRECTION
Burr on hub interfering with disc "float"	File off burr
Set screw backed out and interfering with disc	Retighten set screw; use Loctite® 242 to help secure
MISCELLANEOUS	MISCELLANEOUS
Wiring is restricting disc pack movement	Reroute wiring
Excessive stop time (2 seconds or greater)	Increase brake size/torque or use alternate control method
High Ambient temperature (in excess of 110°F)	Reduce cycle rate or use alternate method of cooling

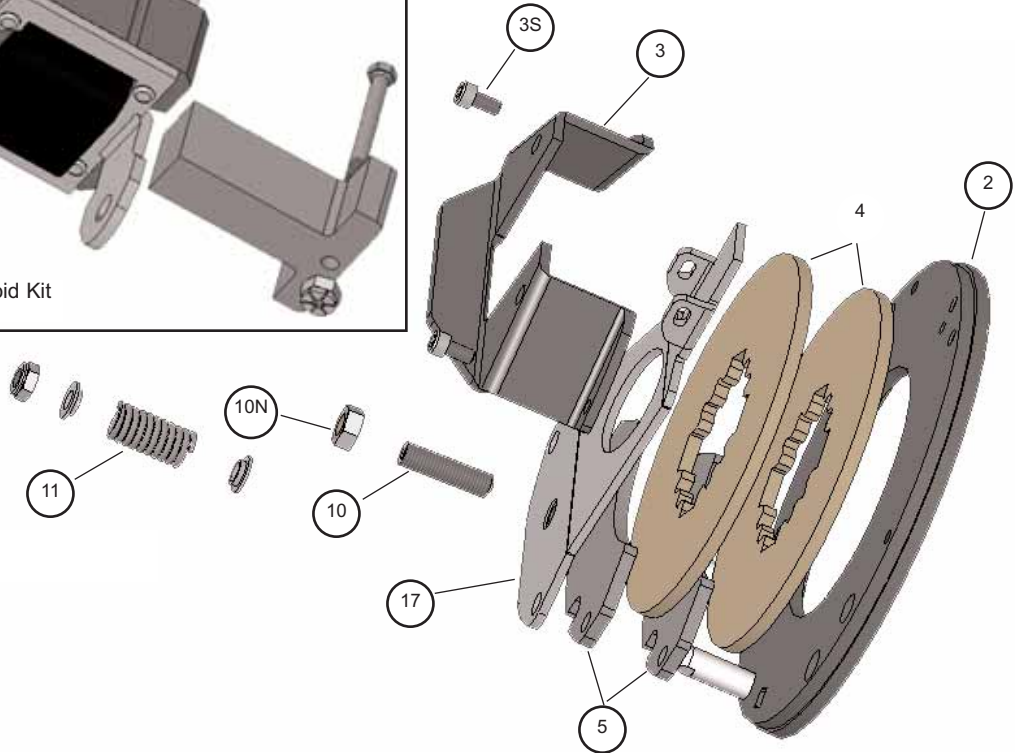
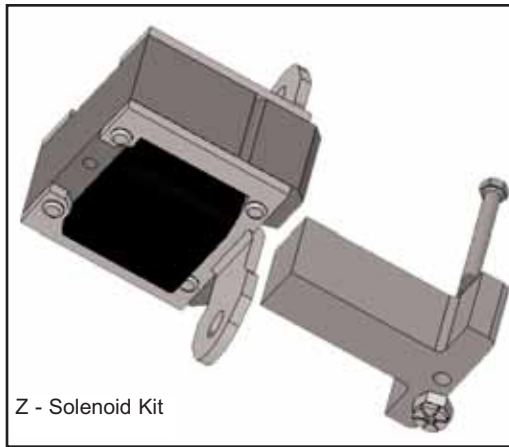
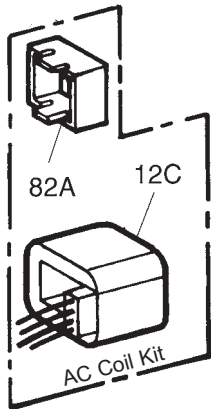

Items with O are for reference only.

* -00 No manual release
-M0 Manual release option

Item	Description	Part No. ↓	Torque lb-ft			
			1.5	3.0	6.0	9.0
	Brake Model # →		1-054-021-X0*	1-054-031-X0*	1-054-041-X0*	1-054-051-X0*
4	Friction Disc Kit	5-66-8462-01	1	1	2	2
Z	Solenoid Kit	5-12-5541-00	1	1	1	1
	Coil Kit					
AC	#J4 115/230	5-96-6457-43	1			
	230/460	5-96-6459-43	1			
	115	5-96-6451-43	1			
	230	5-96-6452-43	1			
	460	5-96-6454-43	1			
	575	5-96-6455-43	1			
	#4 115/230	5-66-6407-33		1	1	
	230/460	5-66-6409-33		1	1	
	115	5-66-6401-33		1	1	
	230	5-66-6402-33		1	1	
	460	5-66-6404-33		1	1	
	575	5-66-6405-33		1	1	
	#K4 115/230	5-66-6457-33				1
	230/460	5-66-6459-33				1
	115	5-66-6451-33				1
	230	5-66-6452-33				1
	460	5-66-6454-33				1
	575	5-66-6455-33				1
MR	Manual Release	5-55-5054-00	1	1	1	1

Z	No. 54 solenoid kit (5-12-5574-00) 1 - Plunger 2 - Flat washer 1 - Frame (including mounting bracket) 1 - Solenoid link cap screw 1 - Solenoid link nut 4 - Shock pads
AC	No. 4 AC coil kit (5-X6-64XX-X3) Coil / Top Plunger guide / Wire nut
MR	Kit (5-55-5054-00) 1 - Support bracket 1 - Release lever 1 - Release spring 2 - Mounting screws

Copyright© 2006 by Rexnord Industries, LLC

*Rexnord Industries, LLC, Stearns Division, 5150 S. International Drive, Cudahy, Wisconsin 53110
(414) 272-1100 Fax: (414) 277-4364 www.stearns.rexnord.com*